

SHOCK ABSORBER KIT FOR
FORD RANGER T6 (2011-2019)

Front Shock Absorber Kit.....Page 1-8

Rear Shock Absorber Kit.....Page 9-14

Mounting Instructions



This page intentionally left blank

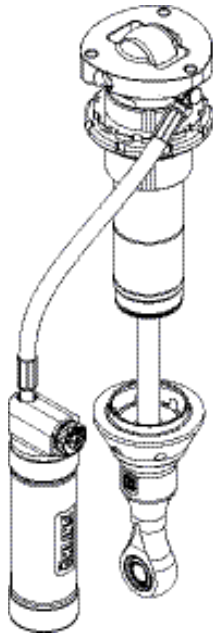

Note!

Please note that this image is a general representation of the product and may differ slightly from your product.

Note!

Please note that during storage and transportation, especially at high ambient temperature, some of the oil and grease used for assembling may leak and stain the packaging. This is in no way detrimental to the product, wipe off the excessive oil/grease with a cloth.

Note!

Before installing this product, check the contents of the kit. If anything is missing, please check an Öhlins dealer.

Kit Contents

Description	Part No	Pcs
1.1 Left Shock absorber	FOV 1W00	1
1.2 Right Shock absorber	FOV 2W00	1
2 Washer	00543-12	2
3 Spring	62462-XX	2
4 Spring clip	62429-01	2
5 Lock ring	62427-01	4
6 Bracker, Reservoir (L)	60006-39	1
7 Bracket, Reservoir (R)	60006-40	1
8 Screw M10x25	00429-34	4
9 Screw M10x20	00429-35	2
10 Washer	00426-08	6
11 Reservoir bracket	05378-20	4
12 Screw M5x22	01046-26	8
13 Screw M5x16	01046-18	8
14 Lock nut M5	00430-04	16
15 Washer	00153-03	12
16 Screw M8x20	00429-36	4
17 Lock nut M8	00430-05	4
18 Washer	00153-01	8
19 Edge clip + Tie-rap	60231-04	4
20 Spacer	10410-15	4
21 C-Spanner	60710-03	1
22 R&T C-Spanner	01796-01	1
23 Sticker set "ÖHLINS"	10207-01	1
24 Owner manual	07440-06	1

Warning!

Before installing this product, read the Öhlins Owner's Manual. The shock absorber is an important part of your vehicle and will affect the stability.

Shock Absorber Kit for Ford Ranger T6 - Front

FOV 1W00

FOV 2W00

Mounting Instructions



MOUNTING INSTRUCTIONS

⚠ Warning!

It is advisable to have an Öhlins dealer install the shock absorber.

⚠ Warning!

If working on a raised vehicle, ensure it is securely supported so that it will not tip over.

👁 Note!

Before mounting this product clean the vehicle thoroughly.

👁 Note!

When working on this product, always see the Vehicle Service Manual for vehicle specific procedures and important data.

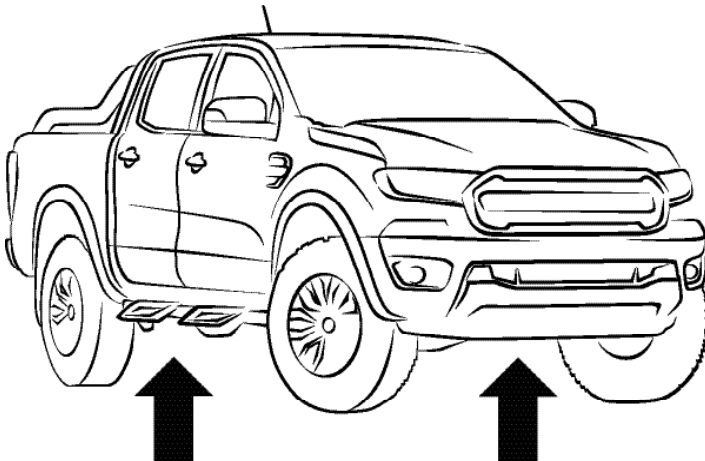

1

Lift the vehicle by using a suitable car lift.

👁 Note!

Please refer the chassis lifting point in the vehicle service manual.

2

Remove the front wheels.

MOUNTING INSTRUCTIONS

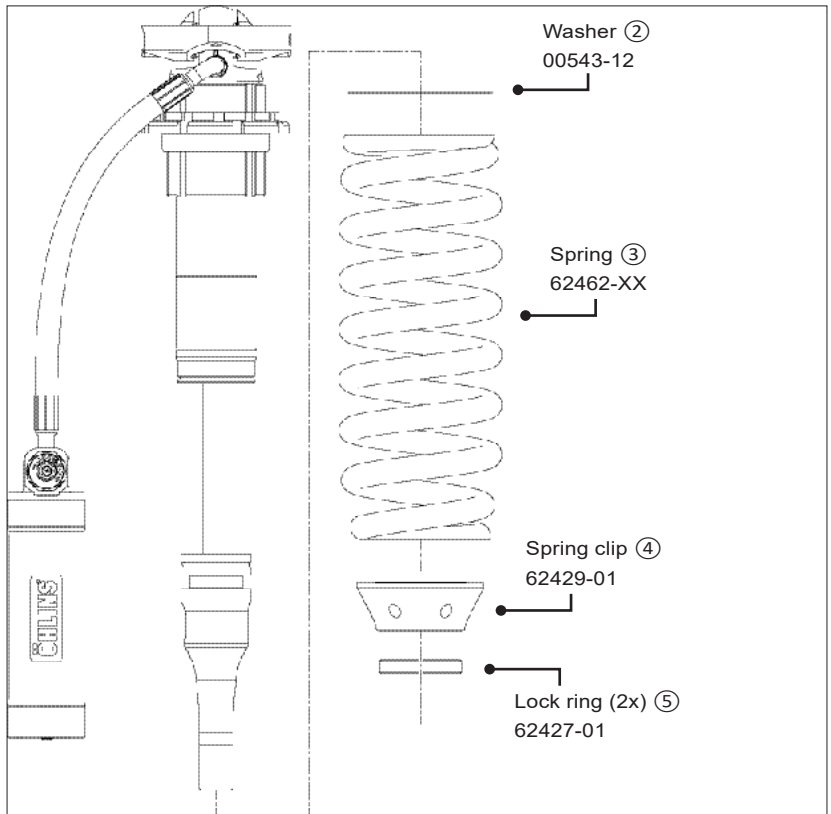
**3 Spring Installation**

- 3.1 Pre-compress the spring by using a spring compressor.
- 3.2 Install the washer (2) underneath the spring seat.
- 3.3 Install the spring (3) onto the damper body.
- 3.4 Install the spring clip (4) thru the end-eye and lock it in place by using the 2 lock rings (5).
- 3.5 Release the spring from the spring compressor making sure that the spring clip and the lock rings are seated properly.

👁 Note!

When installing the springs, reservoir hose and rebound adjuster must be pointed toward the front of vehicle

👁 Note!

For spring recommendation and preload see page 6.

MOUNTING INSTRUCTIONS

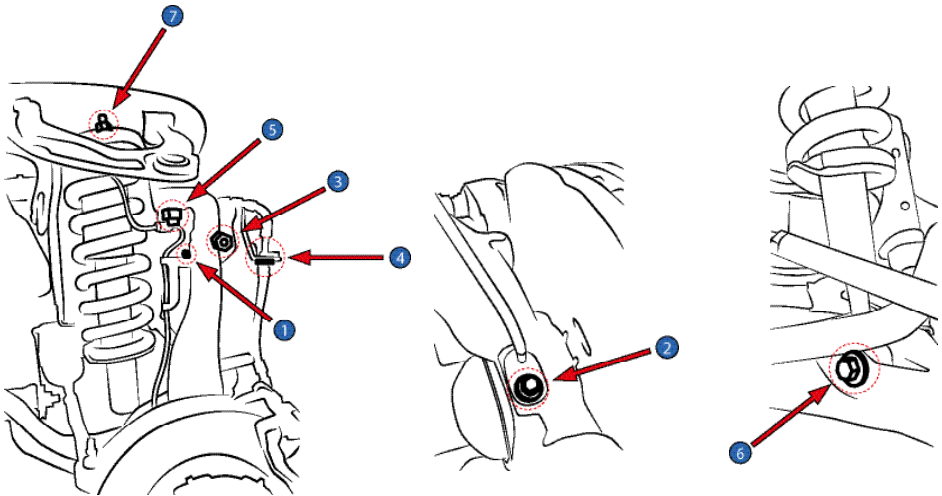

4 Remove OEM Shock Absorber

- 4.1 Loosen the wiring cable bracket ①, and speed sensor ②.
- 4.2 Loosen the anti-rollbar link ③ and disconnect it from the upright.
- 4.3 Release the brake line clamp ④.
- 4.4 Disconnect the upper control arm from the upright by loosening the balljoint nut ⑤.
- 4.5 Loosen the lower mounting screw ⑥.
- 4.6 Loosen the 3 top mount nuts ⑦ then remove the OEM front shock absorbers from the car.

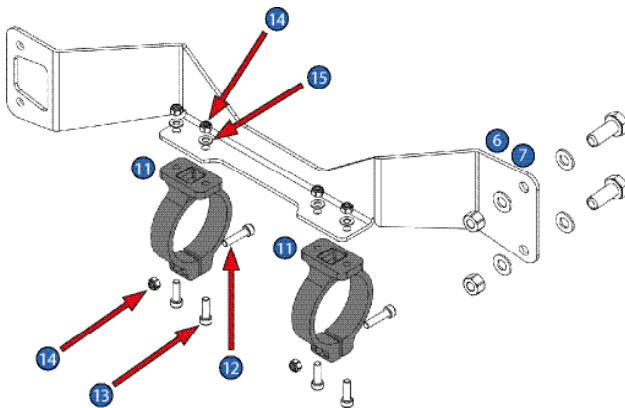

5 Reservoir Bracket

- 5.1 Install 2 reservoir clamps (11) on the reservoir brackets (6) and (7) using respectively 4 screws (13), washers (15), and lock nuts (14).
- 5.2 Mount the reservoir clamps (11) with the lock nuts (14) toward inside of the vehicle.

MOUNTING INSTRUCTIONS

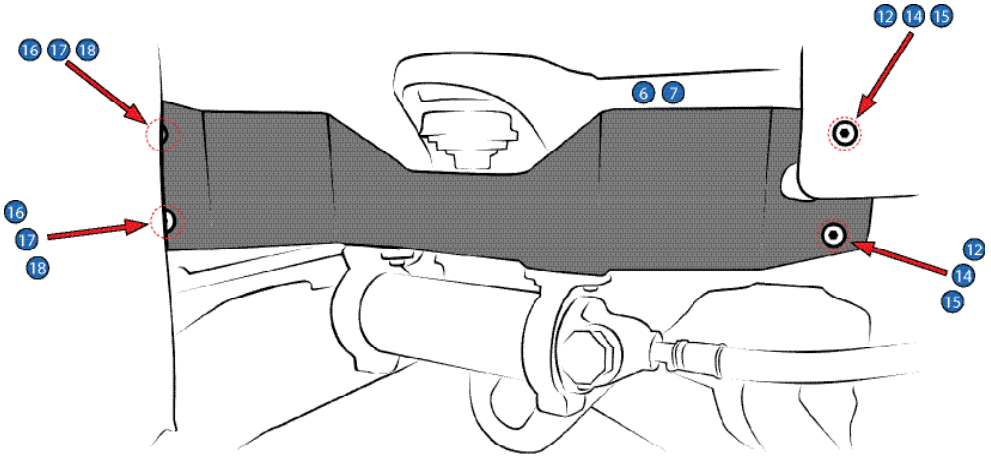

5.3 Assemble the reservoir brackets (6) and (7) on each side of the car.

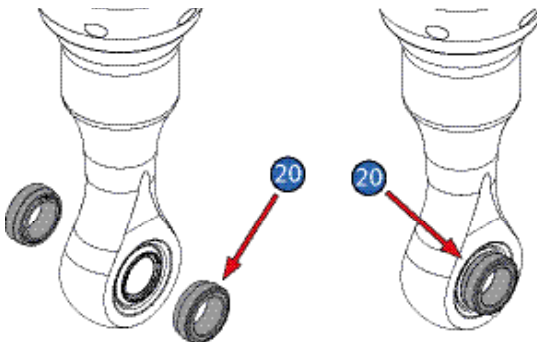
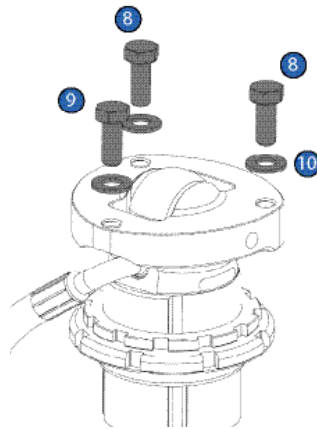

Note!

Secure the hose to prevent it from getting in contact with any moving parts

MOUNTING INSTRUCTIONS

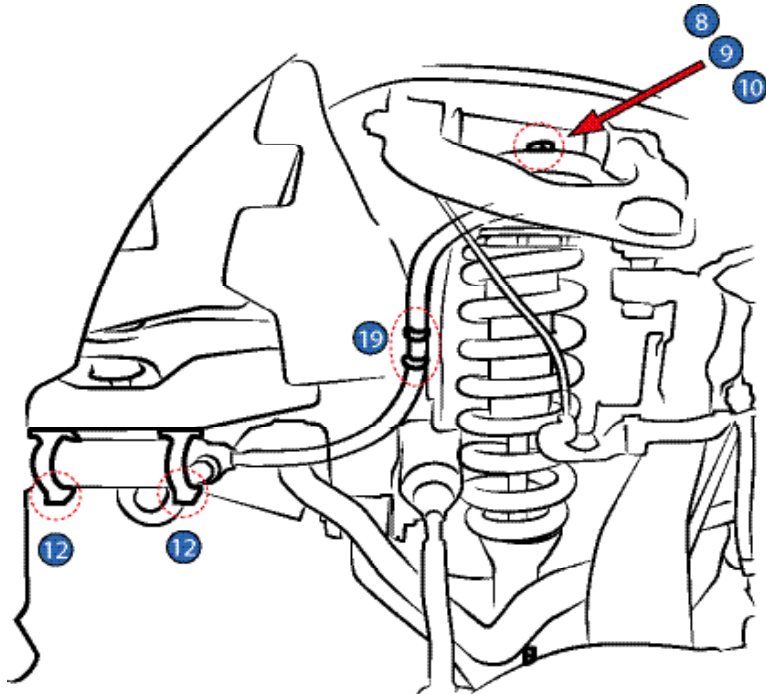
**6 Install Ohlins Shock Absorber**

- 6.1 Install Ohlins shock absorber by placing the end eye in the lower arm and then the top mount in the brace.
- 6.2 Tighten the top mount screws (8) and (9), with washers (10) supplied with the kit. Tightening torque at 44 Nm.
- 6.3 Reverse all the procedures as necessary. Tighten at torque values specified in the vehicle service manual.
- 6.4 Install the reservoirs in the clamp brackets and tighten the 2 screws (12) with tightening torque at 10 Nm.
- 6.5 Use the edge clips with cable ties (19) to fix the hose in position on the chassis.

👁 Note!

Secure the hose to prevent it from getting in contact with any moving parts

ADJUSTMENTS

⚠ Warning!

Before driving, always make sure that the basic settings made by Öhlins are according to recommended Set-up Data. Read about adjustments and setting up in the Öhlins Owner's Manual before you make any adjustments. Contact an Öhlins dealer if you have any questions about setting up.

👁 Note!

Apply the multi-purpose oil to preload adjuster when preload adjustment needed.

👁 Note!

Recheck the vehicle wheel alignment after installed.

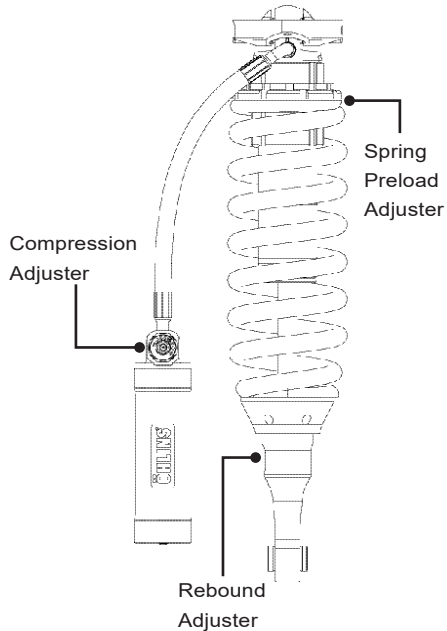

Shock absorber data

Length	520 mm
Stroke	121 mm

SET-UP DATA

Recommended set-up

Paved roads/highway:	
Compression Adjuster	10 Clicks
Rebound Adjuster	15 Clicks
Gravel roads/offroad:	
Compression Adjuster	13 Clicks
Rebound Adjuster	15 Clicks

Spring options

Part No.	62462-08	62462-09
Free spring length	335 mm	335 mm
Spring rate	130 N/mm	140 N/mm
Preload adj.range	[28-44] mm	[28-39] mm
Recommended preload	38 mm	33 mm
Vehicle equipment	Light bull bar Up to 50 kg.	Heavy bull bar/Winch Up to 100 kg.

Öhlins products are subject to continuous improvement and development, therefore, although these instructions include the most up-to-date information available at the time of printing, minor updates may occur.

To find the latest information contact an Öhlins distributor. Please contact Öhlins if you have any questions regarding the contents in this document.

Part no. MI_Ford Ranger_EN_0
Issued 2021-10-06

© Öhlins Asia Co. Ltd. All rights reserved. Any reprinting or unauthorized use without the written permission of Öhlins Racing AB is prohibited.

Öhlins Asia Co. Ltd
700/937 Moo5, Tambol Nongkhaga,
Amphur Phantong, Chonburi Province
20160 Thailand



www.ohlins.com

This page intentionally left blank

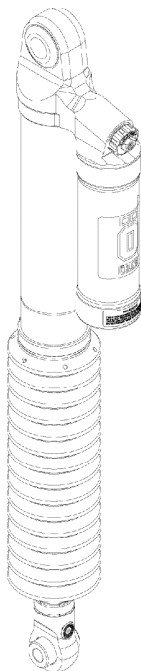

👁 Note!

Before installing this product, check the contents of the kit. If anything is missing, please check an Öhlins dealer.

Kit Contents

	Description	Part No	Pcs
1	Shock absorber	FOV 6W00	2
2	Spacer	60049-04	2
3	Lift block	62417-25	2
4	Pin	62418-01	2

👁 Note!

Please note that this image is a general representation of the product and may differ slightly from your product.

👁 Note!

Please note that during storage and transportation, especially at high ambient temperature, some of the oil and grease used for assembling may leak and stain the packaging. This is in no way detrimental to the product, wipe off the excessive oil/grease with a cloth.

⚠ Warning!

Before installing this product, read the Öhlins Owner's Manual. The shock absorber is an important part of your vehicle and will affect the stability.

Shock Absorber Kit for Ford Ranger T6 - Rear

FOV 6W00

Mounting Instructions



MOUNTING INSTRUCTIONS

⚠ Caution!

Before removing the rear shock absorbers and U bolts, please make sure to secure the rear axle.

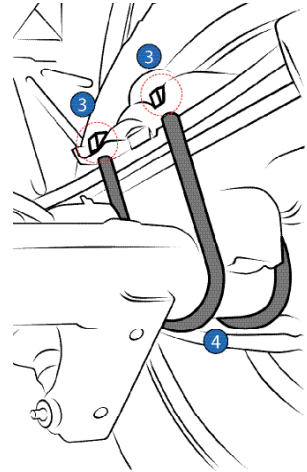
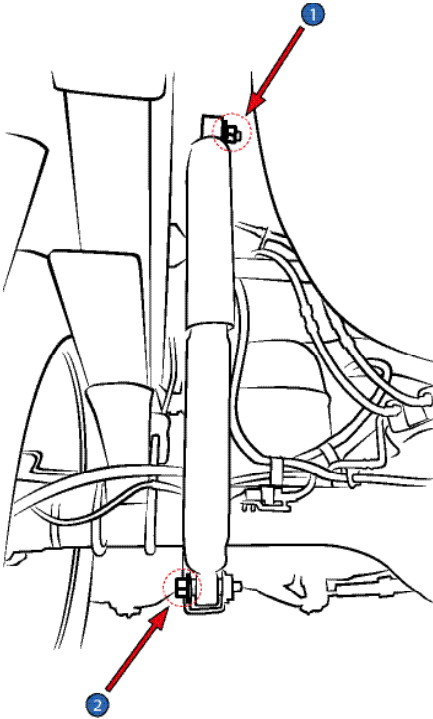

1 Remove OEM Shock Absorber

- 1.1 Remove the OEM shock absorbers from the car loosening nut ① and screw ②.
- 1.2 Loosen the 4 nuts ③ then remove the U-bolts ④.

MOUNTING INSTRUCTIONS

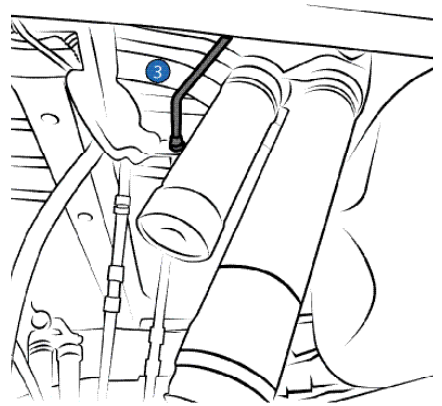
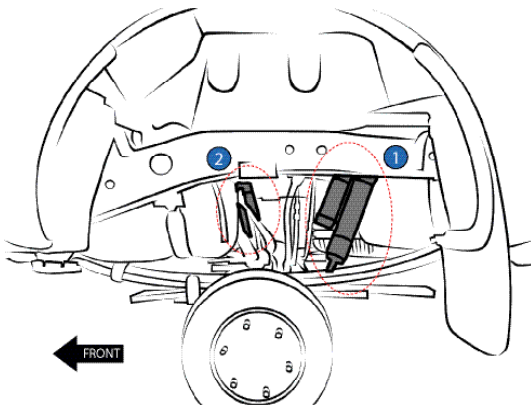
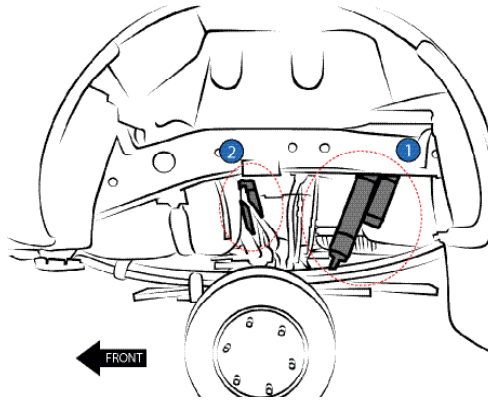

Note!

The orientation of rear shock absorbers may be different between car models

2 Ohlins Shock Absorber Orientation

2.1 On the model without extra fuel tank, both shock absorbers ① and ② are oriented with the reservoir toward the rear of the vehicle.

2.2 On the model with dual fuel tank, the left shock absorber ① is oriented with the reservoir toward the front of the vehicle.

2.3 In the condition of 2.2, the brake line ③ needs to be pushed forward to avoid interferences with the reservoir.

MOUNTING INSTRUCTIONS

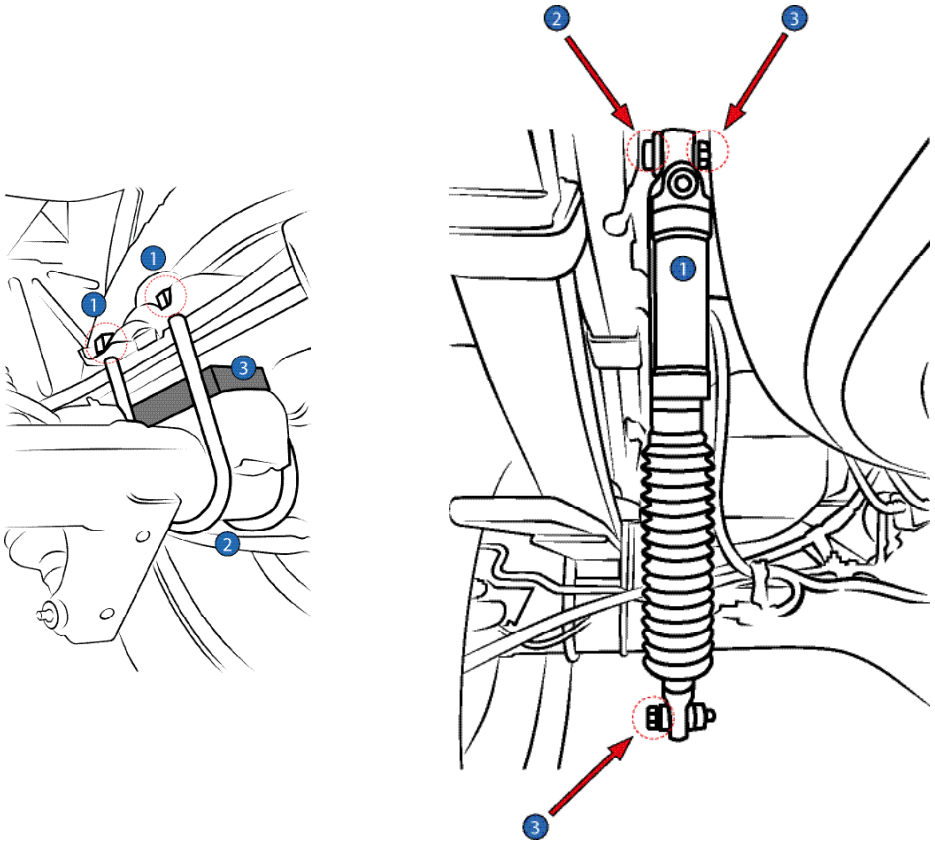

👁 **Note!**

U-bolts are not supplied in the kit. Please ask Öhlins dealers for recommendation.

3 Install Ohlins Shock Absorber

3.1 Install the lift blocks (3) that supplied in the kit between the leaf spring and the rear axle.

3.2 Replace the new 25 mm longer U-bolts (2) then tighten 4 nuts (1) with torque value as specified in the vehicle service manual.

3.3 Install the spacer (2) that supplied in the kit over the top mount pin. (Internal chamfer towards the chassis:

3.4 Install the Ohlins shock absorber (1) then tighten nuts and screws (3) at torques specified in the vehicle user manual.

This page intentionally left blank

ADJUSTMENTS

⚠ Warning!

Before riding, always make sure that the basic settings made by Öhlins are according to recommended Set-up Data. Read about adjustments and setting up in the Öhlins Owner's Manual before you make any adjustments. Contact an Öhlins dealer if you have any questions about setting up.

👁 Note!

Recheck the vehicle wheel alignment after installed.

SET-UP DATA

Recommended set-up

Paved roads/highway:	
Compression Adjuster	15 Clicks
Rebound Adjuster	20 Clicks

Gravel roads/offroad:	
Compression Adjuster	18 Clicks
Rebound Adjuster	20 Clicks

Shock absorber data

Length 640 mm
 Stroke 238 mm

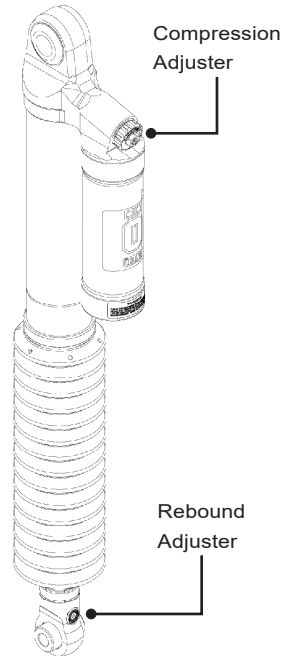

Öhlins products are subject to continuous improvement and development, therefore, although these instructions include the most up-to-date information available at the time of printing, minor updates may occur.

To find the latest information contact an Öhlins distributor. Please contact Öhlins if you have any questions regarding the contents in this document.

Part no. MI_Ford Ranger_EN_0
 Issued 2021-10-06

© Öhlins Asia Co. Ltd. All rights reserved. Any reprinting or unauthorized use without the written permission of Öhlins Racing AB is prohibited.

Öhlins Asia Co. Ltd
 700/937 Moo5, Tambol Nongkhaga,
 Amphur Phantong, Chonburi Province
 20160 Thailand



www.ohlins.com